

## Assignment 9: Dynamic Systems: Differential Equations

Solution (partial answer)

Instructor: Trani

### Problem 1

Consider the mass-spring-damper (MSD) system described in class and shown in Figure 1. The system has been demonstrated in class using the Matlab ODE solver. A 3000 kilogram object is attached to a 4000 N/m spring and a 2000 N/m/s damper as shown in Figure 1. This system is used to mitigate seismic loads in a small building.

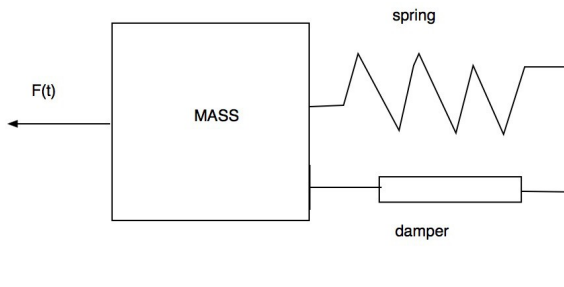
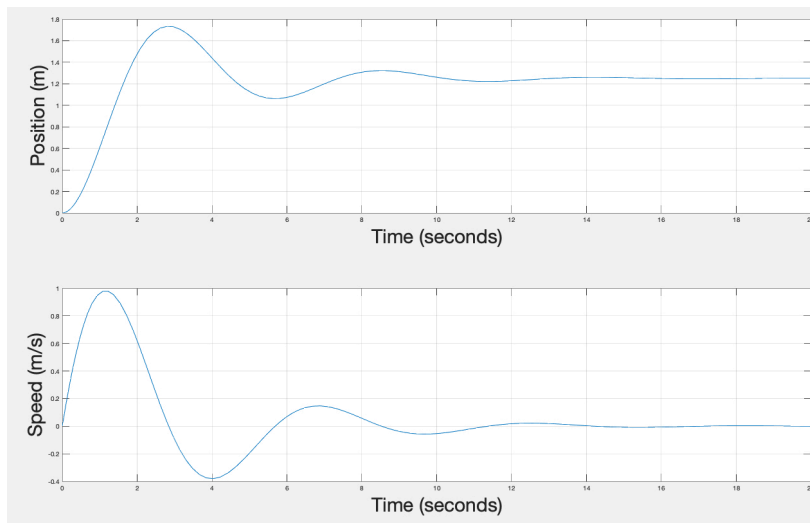

Figure 1. Mechanical System.

### Task 2

Solve the MSD using the Simulink 5th order method. Simulate until the MSD until the position of the mass is near its equilibrium condition (i.e., when oscillation peaks are very close to a steady-state condition). Create a Matlab script that takes the outputs of the Simulink model created in Task 1 and plot the position and velocity profiles of the MSD system as a function of time using two subplots in the same figure.

Using the plot, estimate how long will it take for the MSD system to reach a final displacement position within 5% of its long-term (equilibrium condition). response of the MSD system. Note the system reaches 5% of seated state value at  $t = \sim 9$  seconds.



Position and velocity of MSD system with baseline values.

### Task 3

Suppose that you are in charge of making design changes to the mechanical system. This type of system (called a seismic damper) is used in buildings to dampen oscillations due to earthquakes or wind (see article [http://www.wind.arch.t-kougei.ac.jp/info\\_center/IContent/tamura/10.pdf](http://www.wind.arch.t-kougei.ac.jp/info_center/IContent/tamura/10.pdf)). Your task is to specify the numerical value of a new damper ( $b$ ) so that the MSD reaches 5% of its final displacement in less than 8 seconds. Note that since dampers are expensive, your task is to make the damper light, yet powerful to restore the system quickly to a steady-state condition. Assume a damper weighs 0.2 kg for each N/(m/s) value of the damper constant.

State the mass of the damper that satisfies the criterion.

**$b = 2300$  N/(m/s) seems to work and bring the system within 5% of its final displacement in 8 seconds or less.**

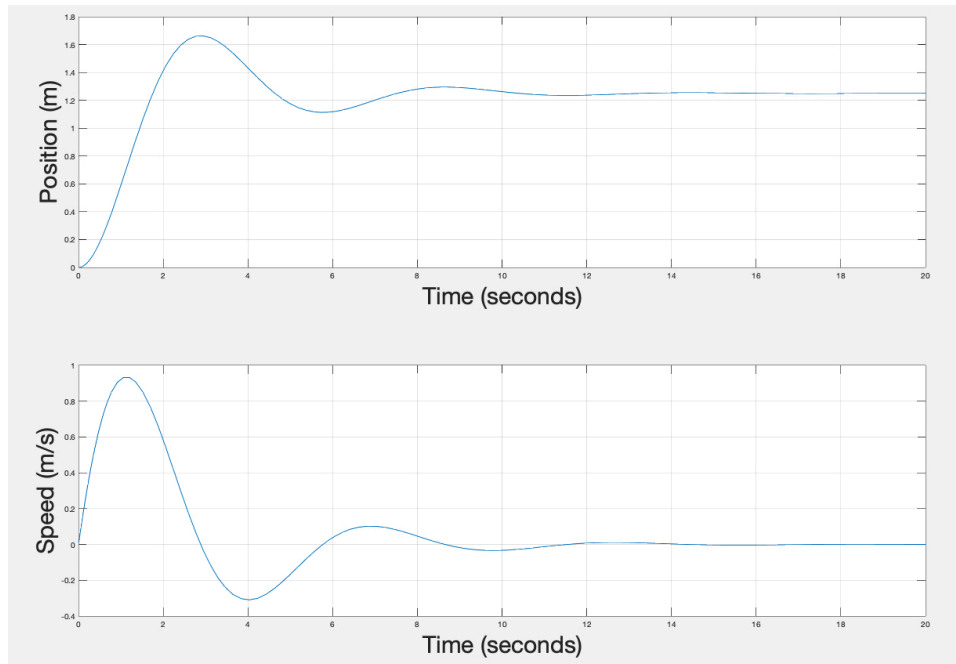

Position and velocity of MSD system with  $b=2300$ .

### Problem 3

Figure 2 shows the runway arrestor system discussed in class.

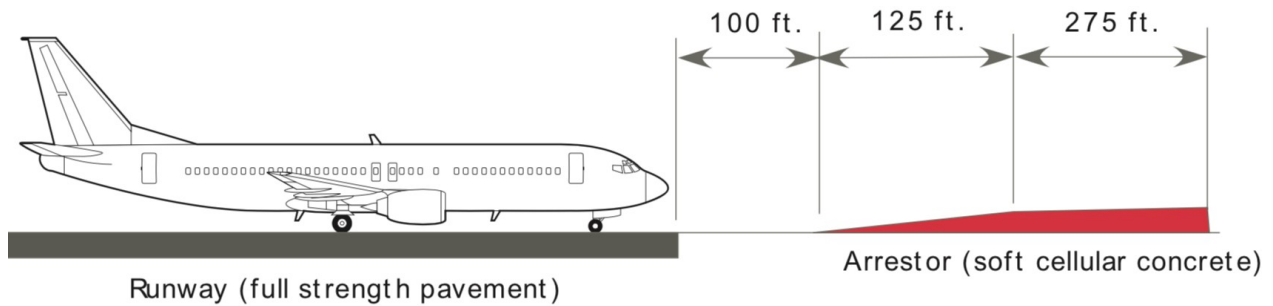

**Figure 2. Runway Arrestor Bed for Problem 3.**

Table 1 shows the laboratory test results of a new type of cellular concrete to be used in the an arrestor bed at Roanoke Regional Airport. The proposed dimensions of the arrestor bed are shown in Figure 2. The full depth of the arrestor bed is proposed to be 23 inches. The arrestor bed ramp increases the depth linearly from 0 to the full arrestor bed in 125 feet.

*Table 1. Coefficient of Friction Data Obtained in the Lab.*

Depth of Arrestor Bed (inches)	Coefficient of Friction ( $\mu$ ) (dim)
0.0	0.000
2.5	0.050
5.0	0.085
7.5	0.110
10.0	0.135
12.5	0.190
15.0	0.245
17.5	0.286
20.0	0.340
22.5	0.420
25.0	0.550
27.5	0.590

## Task 1

```
% Regression analysis for friction data

load ('arrestor_frictionData.m')

% Column 1 = Depth - inches
% Column 2 - Friction coefficient - dim

% 0.0  0.000
% 2.5  0.050
% 5.0  0.085

arrestorDepth = arrestor_frictionData(:,1);
friction      = arrestor_frictionData(:,2);

% Do the regression analysis - use 2nd order polynomial

coefficients = polyfit(arrestorDepth,friction,2);

% Evaluate the polynomial and compare to actual data

depthTest = 0:1:28;    % up to 28 inches
estimatedFriction = polyval(coefficients,depthTest);

% Plot

plot(arrestorDepth,friction,'or',depthTest ,estimatedFriction,'^b--')
xlabel('Arrestor Depth (inches','fontsize',20)
ylabel('Friction (dim','fontsize',20)
grid
```

Polynomial coefficients = [0.000514 0.00682 0.02068] = [A B C]

$\text{friction} = A (\text{arrestorDepth})^2 + B(\text{arrestorDepth}) + C$

The second order polynomial seems to be a good fit. The figure below compares the regression model and the data.

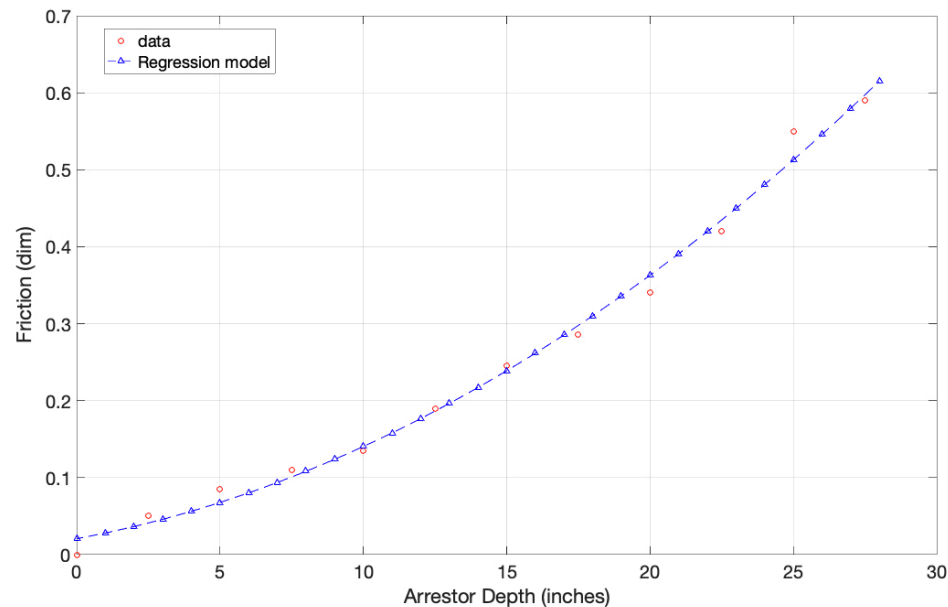

## Task 2

Create a Simulink model to solve the differential equation(s) to calculate the position and velocity of the aircraft assuming an initial speed of 110 km/hr. Your Simulink model should use the polynomial regression created in Task 1. Export the values of velocity, position and acceleration vs. time from your Simulink model and make necessary plots to visualize the system. Estimate the distance traveled by the aircraft to come to a full stop with the given initial conditions.

The proposed arrestor bed has ramp that spans over 125 feet (see diagram). The depth of the ramp at the end point is 23 inches. The slope of the ramp is 0.6035 inches per linear meter of distance traveled. The ramp is 38.1 meters long. The friction coefficient ( $\mu$ ) is now a function of arrestor depth according to the data provided.

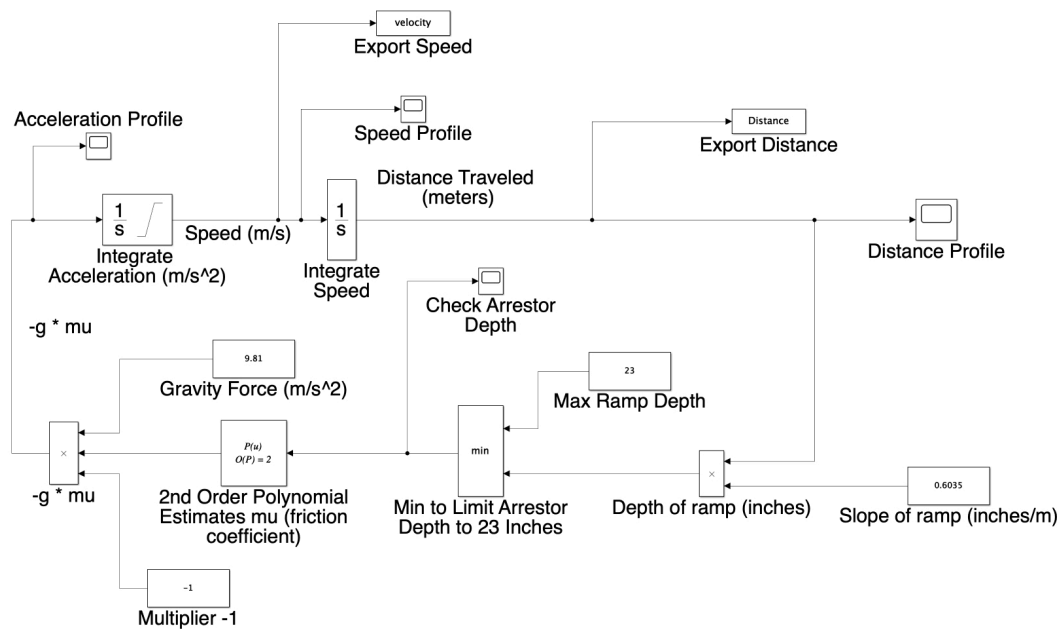

Notes on the diagram above:

- 1) The Max block (called Max Ramp Depth) is used to limit the arrestor bed depth to 23 inches (note that it follows the calculation of arrestor bed depth)
- 2) The arrestor bed depth is calculated using the slope of 0.6035 inches per meter
- 3) The polynomial block has the coefficients estimated in Task 1
- 4) The multiplier block (-1) is used to produce a negative acceleration (m/s-s)
- 5) The initial value of speed of the aircraft at start of the arrestor is 30.56 m/s

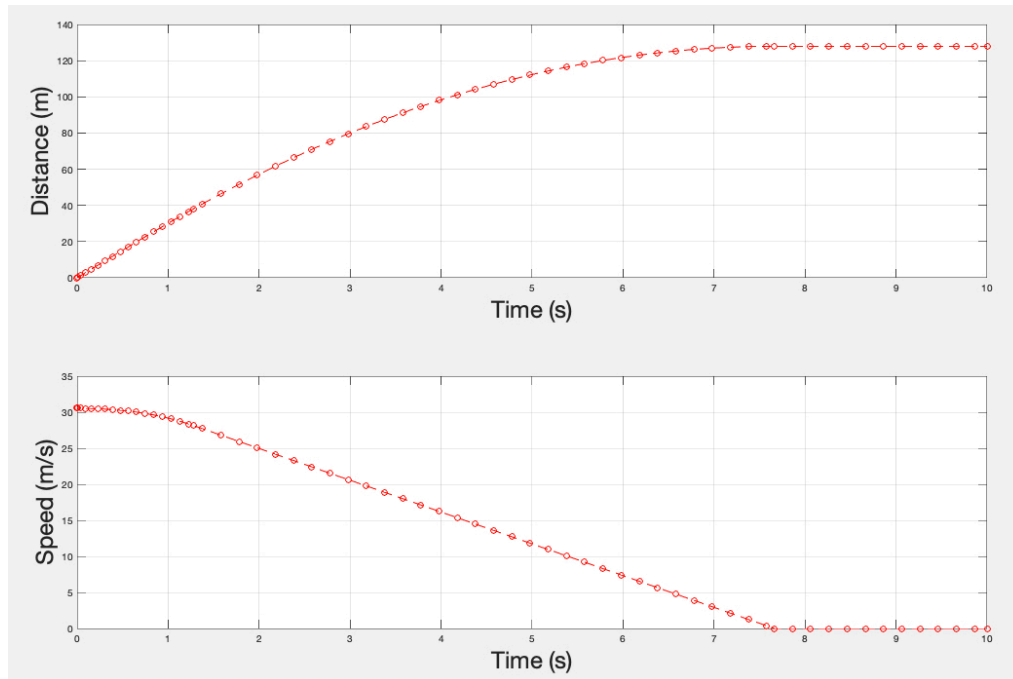

Distance and Speed Profiles of Aircraft on Arrestor Bed (Polynomial Model).

### Task 3

Create a second Simulink model to solve the differential equation(s) to calculate the position and velocity of the aircraft assuming an initial speed of 110 km/hr. Your Simulink model should use the actual data of Table 1 using a table look-up function. Export the values of velocity, position and acceleration vs. time from your Simulink model and make necessary plots to visualize the system.

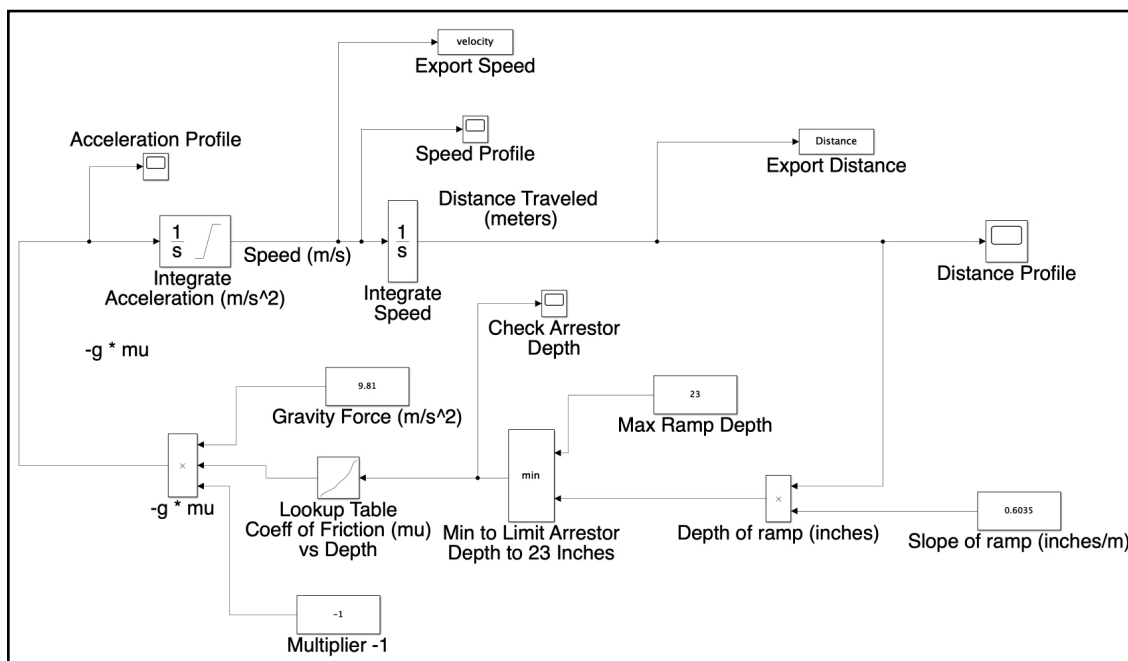

Notes on the diagram above:

- 1) The Max block (called Max Ramp Depth) is used to limit the arrestor bed depth to 23 inches (note that it follows the

calculation of arrestor bed depth)

- 2) The arrestor bed depth is calculated using the slope of 0.6035 inches per meter
- 3) The table lookup function has the values shown in Table 1 (friction vs arrestor bed)
- 4) The multiplier block (-1) is used to produce a negative acceleration (m/s-s)
- 5) The initial value of speed of the aircraft at start of the arrestor is 30.56 m/s

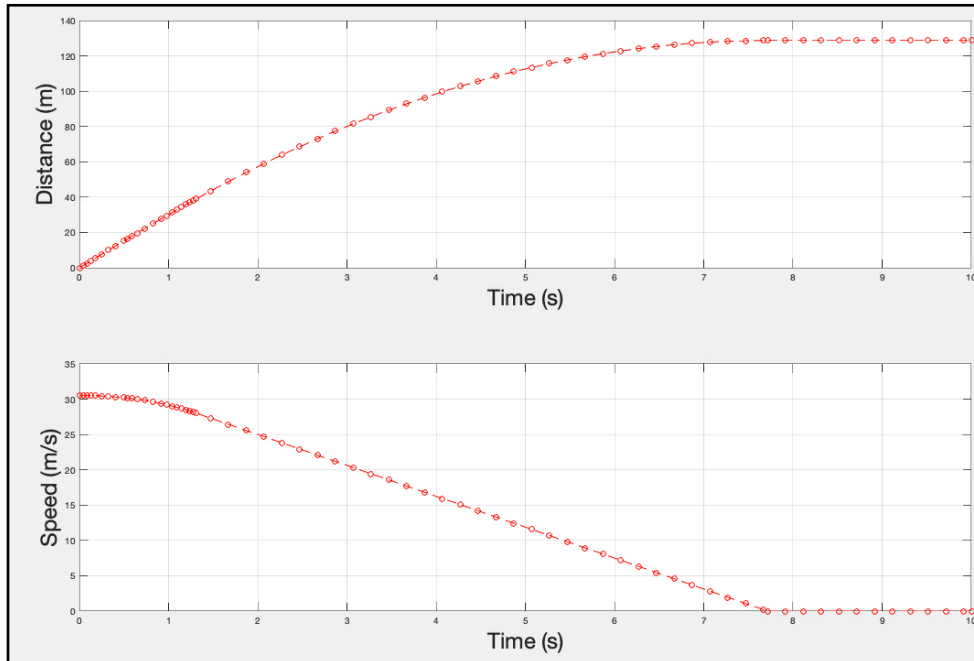

Distance and Speed Profiles of Aircraft on Arrestor Bed (Table Lookup Function Model).

#### Task 4

The aircraft stops in 128 meters (420 feet) and 7.6 seconds. The arrestor is 400 feet long. The arrestor bed is a bit short (by 20 feet). Both models produce similar answers.