

**Quiz 3 (55 minutes)**

Date: December 6, 2013

Instructor: Trani

**Solution**

Your Name \_\_\_\_\_

Pledge \_\_\_\_\_

Use the Word processor of your choice to assemble your solutions. Include all screen captures of your Matlab scripts and plots created as outputs. Create a single PDF file and send via email to: Ross Powers <[rp87@vt.edu](mailto:rp87@vt.edu)> and Yang Zhang <[yang1990@vt.edu](mailto:yang1990@vt.edu)>.

## Problem 1 (50 Points)

Biological treatment using bacteria is a useful technique to treat wastewater solids. The idea is to alter organic matter in the wastewater solids using bacteria in the presence of Dissolved Oxygen (DO). A kinetic equation that explains bacteria growth in a treatment tank is shown in Equation (1). Note that the units in equation (1) are dimensionally correct.

$$\frac{dx}{dt} = kx \left[ 1 - \frac{x}{x_{eq}} \right] \quad (1)$$

where:

$x$  = concentration of bacteria (g/l)

$x_{eq}$  = carrying capacity of bacteria (g/l)

$k$  = bacteria growth constant (1/hr)

### Task 1 (20 points)

Create a Matlab Simulink model to estimate the bacteria growth given the following initial conditions:

$x_0$  = initial bacteria concentration of 0.02 g/l

$k = 0.1$  (1/hr)

$x_{eq} = 100$  g/l

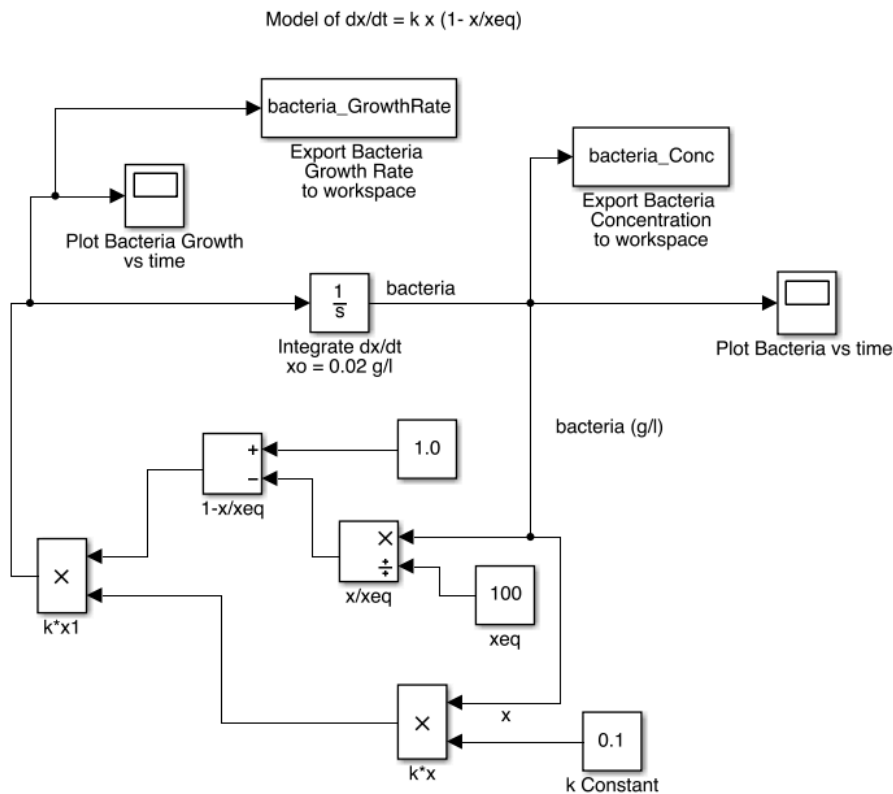

Figure 1. Simulink Model of Bacteria Growth.

Note that this Simulink model exports 4 variables to the Simulink Output structure. Here is the output structure in the workspace:

```
bacteria_Conc: [796x1 double]      % from Simulink Simout plot
bacteria_GrowthRate: [796x1 double] % from Simulink Simout plot
tout: [796x1 double]              % directly from Simulink ( contains values of time)
xout: [796x1 double]              % directly from Simulink ( contains values of bacteria concentration)
```

### Task 2 (20 Points)

Using the model created in Task 1, estimate the growth of bacteria in a wastewater treatment plant over 150 hours. Plot the bacteria concentration as a function of time. Make the plot in Matlab so that you can control the properties of the plot and label the axes appropriately. Also plot the rate of change of bacteria growth over time.

The results of the Simulink model can be exported to two new variables in Matlab as follows:

```
time=out.get('tout');
bacteria=out.get('bacteria_Conc');
```

The results can be plotted in Matlab using the following commands. Figure 1 illustrates the resulting plot.

```
figure
plot(time,bacteria,'o-r')
xlabel('Time (hrs)', 'fontsize',20)
ylabel('Bacteria Concentration (g/l)', 'fontsize',20)
grid
```

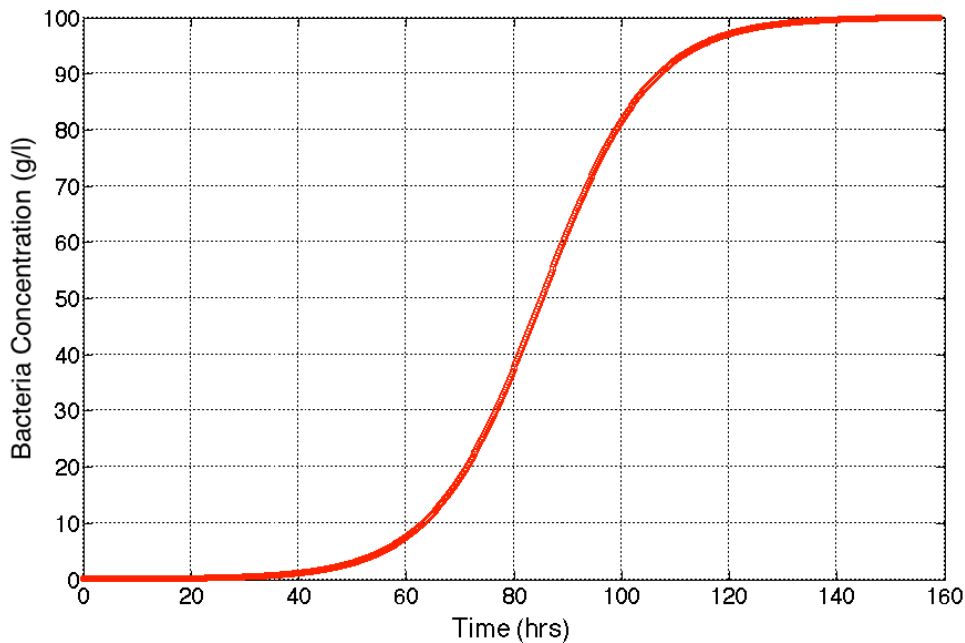

Figure 2. Plot of Bacteria Concentration vs. Time in Matlab.

To export the bacteria growth rate ( $dx/dt$ ) I use the following change in variable.

```
bacteria_GrowthRate=out.get('bacteria_GrowthRate');
```

The results can be plotted in Matlab using the following commands. Figure 2 illustrates the resulting plot.

```
plot(time,bacteria_GrowthRate,'o-b')  
xlabel('Time (hrs)','fontsize',20)  
ylabel('Bacteria Growth Raten (g/l/h)','fontsize',20)  
grid
```

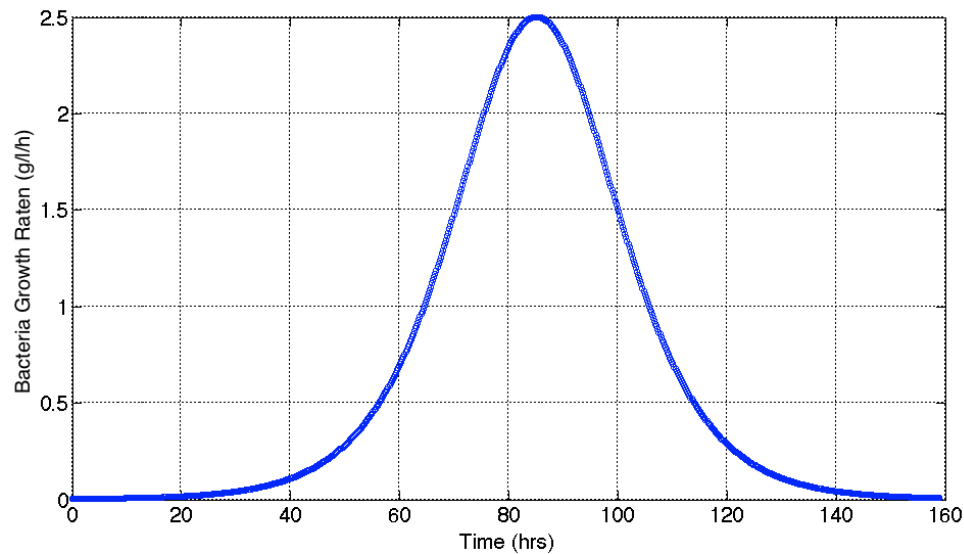

Figure 3. Plot of Bacteria Growth Rate vs. Time.

### Task 3 (10 Points)

Using the plot generated in Task 2 estimate the critical time ( $t^*$ ) when the bacteria concentration reaches 80 g/l. Write down the value of ( $t^*$ ) in your exam solution.

```
>> bacteria_growthForSimulink  
>> criticalTime = interp1(bacteria,time,80)  
criticalTime = 99.0331 hours
```

## Problem 2 (50 Points)

You are a civil/environmental engineer working for the Virginia Department of Transportation. Your task is to estimate the fuel and emissions produced by vehicles driving around Blacksburg. The file "fuelEmissionsData.m" contains the fuel consumption (l/s) and emission rates (Hydrocarbons, CO, and NOx) produced by a small car. The file has the following information:

```
% Fuel and emissions data for a small car
% Column 1 = speed in km/hr
% Column 2 = fuel consumption (l/s)
% Column 3 = HC emissions in (mg/s)
% Column 4 = CO emissions in (mg/s)
% Column 5 = NOX emissions in mg/s
```

```
0 0.000210000000000000 0.214000000000000 1.67500000000000 0.175000000000000
10 0.000280000000000000 0.248000000000000 1.94800000000000 0.224000000000000
```

### Task 1 (20 Points)

Create a Matlab script to read the fuel and emissions rate data provided in the text file "fuelEmissionsData.m". Plot the fuel consumption (l/s) vs. speed (km/hr) and obtain a 4th order polynomial approximation of fuel consumption (l/s) as a function of speed (km/hr) as follows:

$$fuel = AV^4 + BV^3 + CV^2 + DV + E$$

where:

$$fuel = \text{fuel consumption (l/s) and } V = \text{speed (km/hr)}$$

Save the coefficients of the polynomial for later use.

Repeat the process for HC (Hydrocarbon emissions). This time use a 7th order polynomial to estimate HC emission rate (mg/s) as a function of speed (km/hr). Write down (or copy and paste) the two polynomial equations in your exam solution.

```
1 % Script to read fuel and emissions data
2 % Script also finds two polynomial regressions
3 % to relate fuel consumption and speed
4 % and HC emissions and speed
5
6 load fuelEmissionsData.m
7
8 % Column 1 = speed in km/hr
9 % Column 2 = fuel consumption (l/s)
10 % Column 3 = HC emissions in (mg/s)
11 % Column 4 = CO emissions in (mg/s)
12 % Column 5 = NOX emissions in mg/s
13
14 % 0 0.000210000000000000 0.214000000000000 1.67500000000000
15 % 10 0.000280000000000000 0.248000000000000 1.94800000000000
16 % 15 0.000320000000000000 0.280000000000000 2.43000000000000
17
18 % rename variables
19
20 speed = fuelEmissionsData(:,1);
21 fuel = fuelEmissionsData(:,2);
22 HC = fuelEmissionsData(:,3);
23
24 ceoffFuel = polyfit(speed,fuel,4); % fourth order polynomial
25 ceoffHC = polyfit(speed,HC,7); % seventh order polynomial
```

```
coeffFuel
1.0e-03 * [
0.000000021312019
-0.000002677365501
0.000117138065842
0.005966987492127
0.210874537777906]
```

```
coeffHC =
[ 0.000000000000296
-0.000000000081402
0.000000009448957
-0.000000558547833
0.000018588701551
-0.000308328858639
0.008116178936038
0.184907401171486];
```

## Task 2 (15 Points)

Using the two polynomial equations found in Task 1, create a **Matlab function** to estimate the fuel consumption and HC emissions. Your Matlab function should have two outputs: 1) fuel consumption (l/s) and 2) HC emissions (mg/s). The Matlab function has one input variable (speed in km/hr). In the Command Window, test your function for a speed of 36 km/hr. Write down this value in your exam solution.

```
1 % Function to be integrated using Matlab numerical integration techniques
2 %
3 % Programmer: A. Trani
4 % date: 03/12/07
5 %
6 function [fuel,HC]=fuelEmissionsFunction(speed)
7
8 % Coefficients of the 4th and 7th order polynomial - derived graphically in Matlab
9
10 coeffFuel = [2.13120192740864e-11,-2.67736550123700e-09,1.17138065842271e-07,...
11 5.96698749212696e-06,0.000210874537777906];
12
13 coeffHC = [2.95854696569648e-13,-8.14022104017426e-11,9.44895732341318e-09,-5.58547833318616e-07,...
14 1.85887015512934e-05,-0.000308328858638566,0.00811617893603762,0.184907401171486];
15
16 fuel = coeffFuel(1) * speed.^4 + coeffFuel(2) * speed.^3 + coeffFuel(3) * speed.^2 + coeffFuel(4) * speed + coeffFuel(5);
17
18 HC = coeffHC(1) * speed.^7 + coeffHC(2) * speed.^6 + coeffHC(3) * speed.^5 + coeffHC(4) * speed.^4 + coeffHC(5) * speed.^3 + ...
19 coeffHC(6) * speed.^2 + coeffHC(7) * speed + coeffHC(8);
20
21 end
```

The following statement is used to test the Matlab function created.

```
[fuel,HC]=fuelEmissionsFunction(36)
```

fuel = 4.8838e-04 liters

HC = 0.4240 mg

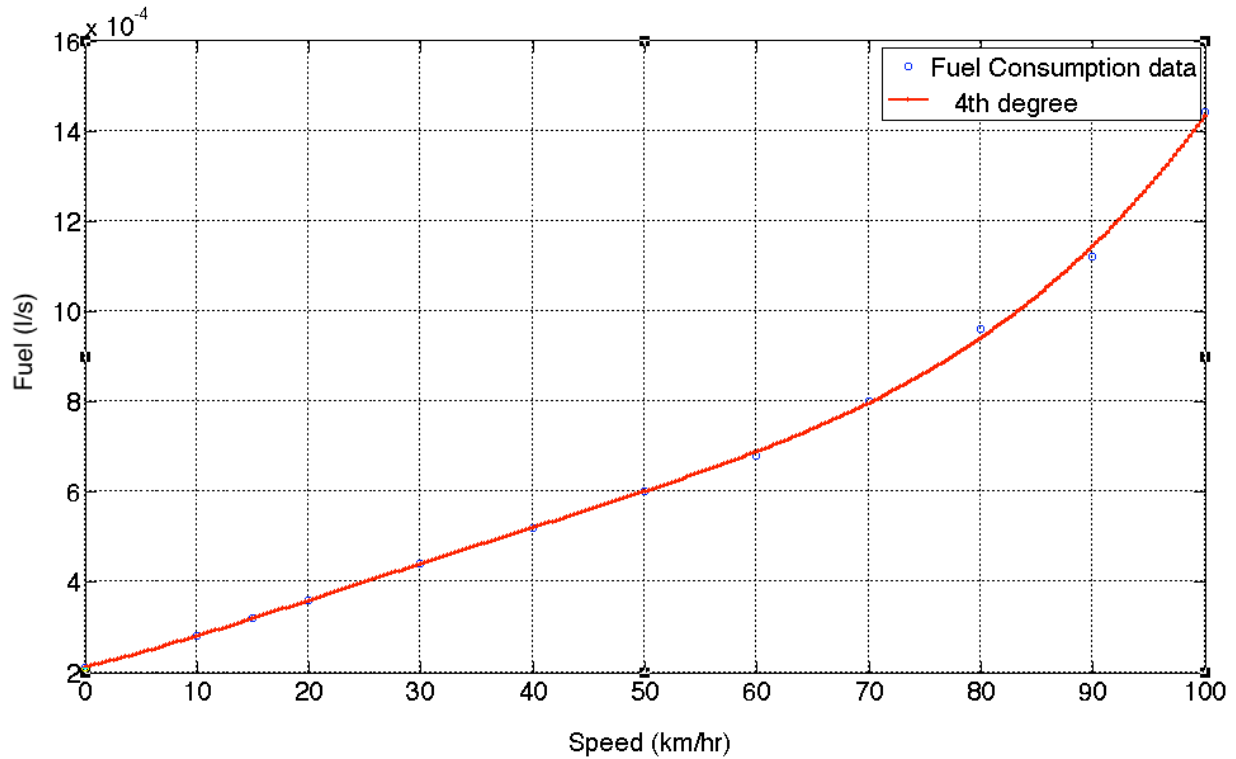

Figure 4. Fuel Consumption vs. Speed.

### Task 3 (15 Points)

Create a second Matlab script to load the vehicle speed profile data (file name is "BCB\_drivingData.m") collected while driving around Blacksburg. The data file contains the following information in the driving profile:

```
% Data for small car driving in Blacksburg
```

```
% Column1 = time (seconds)
```

```
% Column 2 = speed (mph)
```

```
% Column 3 = speed (km/hr)
```

```
0 0.0 0.00
```

```
1 0.0 0.00
```

Using the Matlab function created in Task 2 estimate the fuel consumption (l/s) and HC emissions rate (mg/s) for each data point in the driving profile. Plot the fuel consumption and HC emissions rate as a function of time. Label accordingly.

```

27 % Task 3 load the BCB driving data
28
29 % Data for small car driving in Blacksburg
30 % Column 1 = time (seconds)
31 % Column 2 = speed (mph)
32 % Column 3 = speed (km/hr)
33
34 % 0 0.0 0.00
35 % 1 0.0 0.00
36 % 2 0.0 0.00
37
38 load BCB_driving_data.m
39
40 % define variables
41
42 time = BCB_driving_data(:,1);
43 speed = BCB_driving_data(:,3);
44
45 % Calculate the fuel used every second
46
47 [fuel,HC]=fuelEmissionsFunction(speed);
48
49 figure
50 plot(time,fuel,'or')
51 xlabel('Time (s)')
52 ylabel('Fuel (l/s)')
53 grid
54
55 figure
56 plot(time,HC,'o')
57 xlabel('Time (s)')
58 ylabel('HC Emissions Rate (mg/s)')
59 grid

```

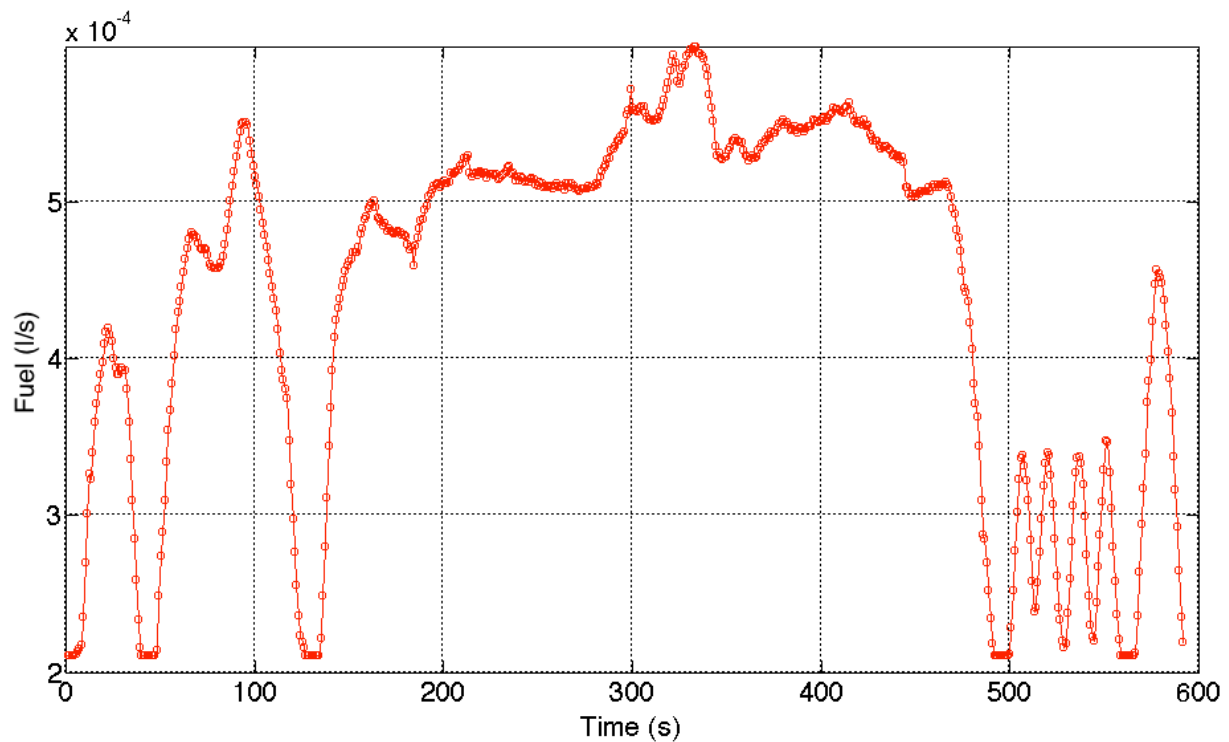

Figure 5. Fuel Consumption vs. Driving Time in Blacksburg Cycle.



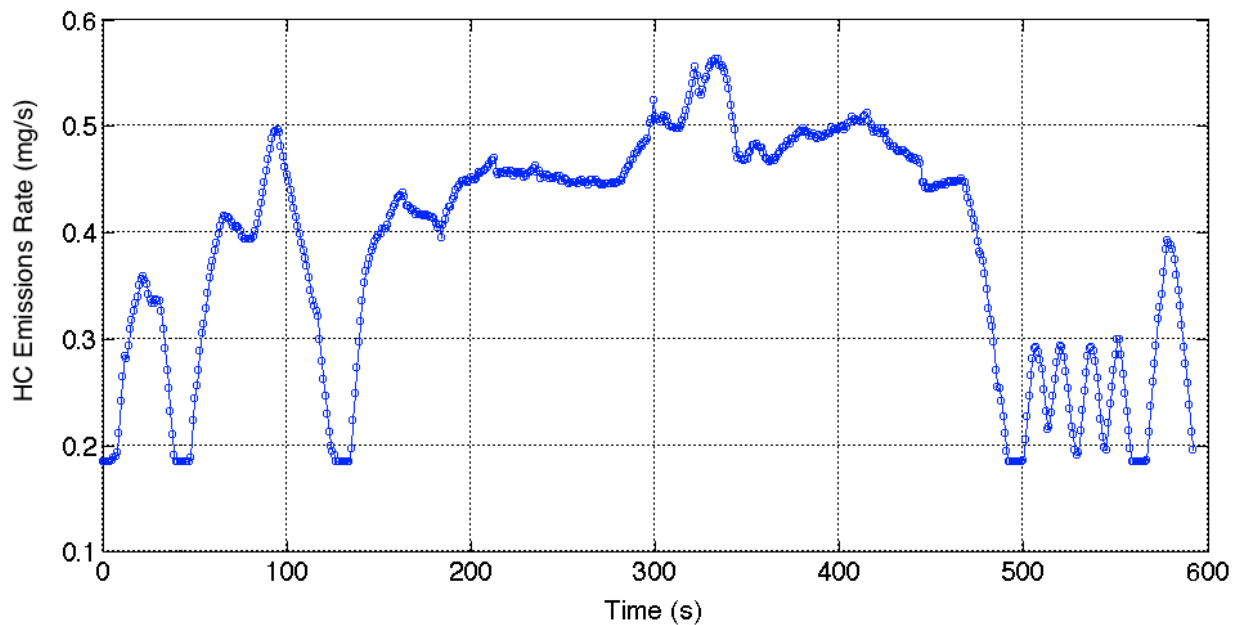

Figure 6. HC Emissions Rate vs. Driving Time in Blacksburg Cycle.

**Bonus Task (5 Points)**

Find the total fuel consumed and HC emissions produced while driving around Blacksburg.

Use Numerical integration to find the total area under curves presented in Figure 5 and 6.

```
>> totalFuel = trapz(time,fuel)
```

```
totalFuel = 0.262 liters of fuel
```

```
>> totalHC = trapz(time,HC)
```

```
totalHC = 231.6 mg
```