

Assignment 6: Maneuvering Analysis and ATC

Date Due: October 21, 2013

Instructor: Trani

Problem 1

One of the fuel savings initiatives under NextGen is to conduct Continuous Descent Approaches (CDA) to busy airports. A sample CDA approach is shown in Figure 1. The CDA approach starts x minutes later (called CDA distance offset) than the normal approach for our analysis. The aircraft initially is straight and level at 35,000 feet and flying at Mach 0.76. A typical approach to a busy airport like LAX involves one or more step down segments as shown in Figure 1. Figure 2 shows actual flight paths extracted from radar data provided by the FAA for a terminal design study. The data applies to large twin-engine transport aircraft. Note that according to Figure 2, below 10,000 feet both profiles will follow the same trajectory.

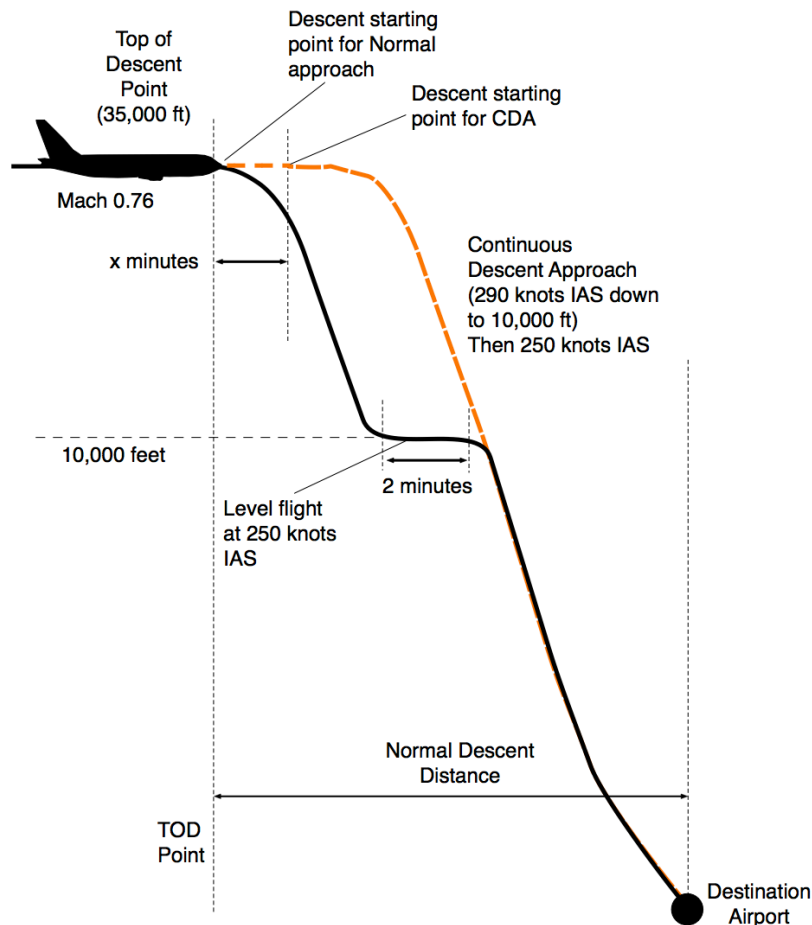

Figure 1. CDA Approach Compared to Typical Approach to LAX Airport.

- a) Determine the value of x (CDA distance offset) that makes the two profiles similar below 10,000 feet.

- b) Using the Boeing 737-800 class transport aircraft in our course material, estimate the fuel savings for a single flight to LAX using the CDA technique. Assume the mass at the TOD point is 58,000 kg. The speed parameters of the approach are provided in Figure 1. Assume the idle thrust is constant at 1/12 of the maximum generated at altitude. In your calculations consider the normal approach having a 2 minute step at 10,000 feet. During the step segment, the aircraft flies straight and level and thus the aircraft engines generate thrust to overcome drag.
- c) Read the paper about CDA approaches by Richard Copenbarger et al. (Journal of Aircraft, Volume 46, 2009) (<http://www.aviationsystemsdivision.arc.nasa.gov/publications/2009/AIAA-39795-675.pdf>) and comment on the possible fuel savings reported in the literature. Compare to your calculations.

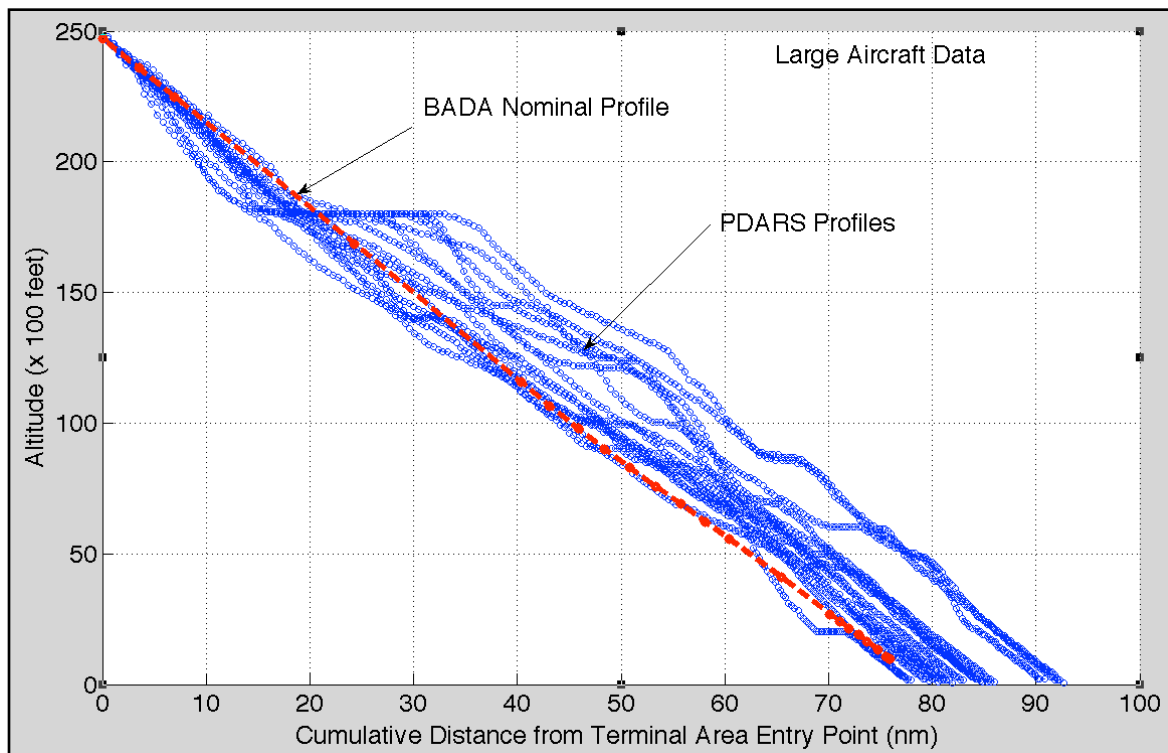

Figure 2. Nominal and Observed Descent Profiles at LAX Airport. Twin Engine Aircraft.

Problem 2

On a busy day, London Heathrow Airport approach control stacks many aircraft in holding patterns as shown in Figure 3. London approach control instructs pilots to fly a standard 4-minute pattern with one minute per side and one minute in the 180-degree turns. On this busy day, the controller instructs a pilot flying a narrow body aircraft (like the Boeing 737-800 class vehicle we use in class) to fly the pattern at 15,000 feet and 250 knots (IAS).

- a) Estimate the fuel burn consumed in the 4-minute holding pattern for the aircraft in question.

- b) Estimate the thrust setting (how much thrust is needed to keep the aircraft in steady and level flight) on both the straight and the turning segments of the holding pattern.
- c) Find the radius of the turn for the aircraft flying the holding pattern.
- d) What is the bank angle (in degrees) to fly the holding pattern?

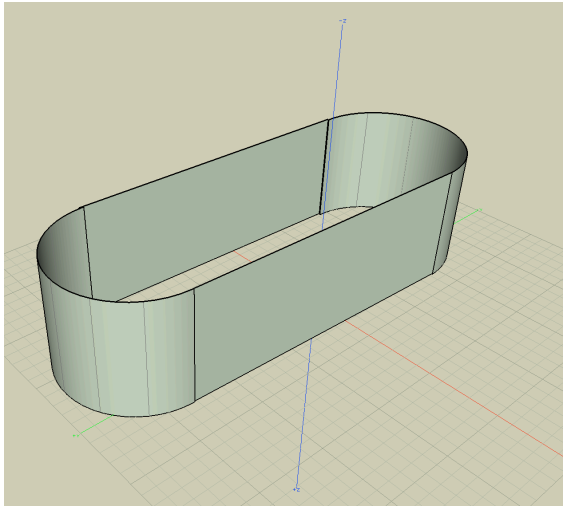

Figure 3. Sample 3D view of a Holding Pattern near an Airport.

Problem 3

Watch the video about KLM Operations Control Center (<http://www.youtube.com/watch?v=JGGRbIvDZVo>) to understand the issues on airline flight planning and operations. Briefly answer the following:

- a) What type of aircraft is flight KLM 601 to LAX showcased in the movie?
- b) Explain the broad range of problems the OCC is responsible for even when a flight is in the air.

Problem 4

Read Chapter 14 of the Pilot's Handbook of Aeronautical Knowledge (http://www.faa.gov/regulations_policies/handbooks_manuals/aviation/pilot_handbook/) and Chapter 1 of the Instrument Procedures Handbook (http://www.faa.gov/regulations_policies/handbooks_manuals/aviation/instrument_procedures_handbook/media/CH-01.pdf). Briefly answer the following:

- a) Explain the differences between airspace Classes B, C and D.
- b) What type of activities occur inside Special Use Airspace?
- c) Define what is required navigation performance (RNP).
- d) What is the typical RNP in the enroute and terminal airspace today in the NAS?
- e) According to the IPH, the Precision Radar Monitor improves the safety of operations. Explain why.